



GRUPE SEFMAT

RIPACK®

USER'S GUIDE

RIPACK 3000

RIPACK 3000 +



**YOUR PROTECTION
BY EXCELLENCE**

**REGISTER YOUR PRODUCT
ONLINE WARRANTY CONTRACT**

RIPACK.COM/EN/REGISTER-A-PRODUCT



RIPACK ACCESSORIES

MODULAR EXTENSIONS

Quick and easy assembly of one or more extension wands on the Ripack Series 3000 heat gun.

All components are integrated and protected from the environment, use extension wands to work quickly and easily.



PIVOTING ARM REST

The pivoting arm rest provides increased comfort during use with an extension and folds away after use.



GAS CYLINDER CART

Ideal to hold and carry the gas cylinder safely, this accessory offers portability in conformity with industrial insurance requirements.

The gas cylinder cart increases the operator's productivity thanks to a greater ease in working.



GAS HOSE REEL WINDER



Heavy duty construction for industrial application : corrosion resistant powder coated steel, four-direction non-snag rollets reducing hose wear abrasion.

Possible mounting on wall, ceiling on floor.

Provided with swivelling support for a greater ease of work. Adjustable guiding arm for horizontal or vertical hose release.

MULTICOVER FILM SEALERS

The Multicover sealers allow to make pallet covers and bags from rolls of shrink-film when required and in any size.

Make savings by avoiding useless stock of various heights and sizes.



MULTICOVER 940/950 :
Ripack Heat Gun Sealing



MULTICOVER 960 :
Electrical impulse sealing



2nd reel in option



MULTICOVER 9503 FILM DISPENSER

TURBOPACK SHRINK COLUMN

INDEPENDENT AND MOBILE

The Turbopack is moved to the pallets, thus avoiding the handling of unsteady loads.

FLEXIBLE

No limitation in length or width of the load. Heating height adjustable from 1,20 m / 47'' up 2,40 m / 95'' (2,20 m / 86'' with optional visor).

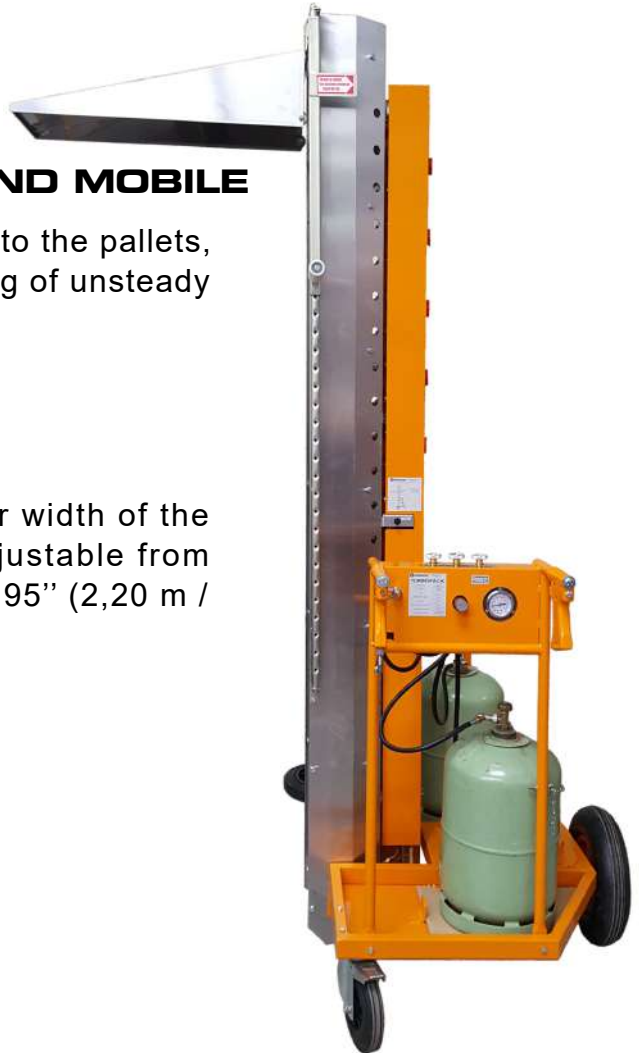

CALPACK PALLET RAISER

Quick and easy to set up, the Calpack allows the film to shrink under the pallet. The load is thus perfectly stabilised with the pallet. Calpack can be used as well with a pallet-truck or a fork-lift.



TOOL BAG CONTENT



WRENCH

SECURIPACK
PRESSURE
REGULATOR

SWIVEL
CONNECTOR

8 M GAS
HOSE

USER'S GUIDE
MEMO



GROUPE SEFMAT

RIPACK®

RIPACK 3000
RIPACK 3000 +

**HAND-HELD PROPANE-FIRED SHRINK GUN FOR
SHRINK-WRAPPING PLASTIC FILMS**

USER'S GUIDE











CONTENTS

WARNINGS.....	8
OPERATION	13
CONNECTIONS.....	14
EXAMPLES OF USE.....	17
MAINTENANCE.....	20
SPARE PARTS.....	23
WARRANTY.....	25
EXPLODED VIEW.....	27
SPARE PARTS LIST.....	29

WARNINGS



TO BE READ BEFORE STARTING FOR THE FIRST TIME

	Do not use this device in regulated areas with specific fire or explosion hazards.
	Do not use the device to shrink the plastic film on a floor made of combustible material (wood, plastic, etc...).
	Delineate a working area such that the tip of the thermal lance is always at least more than 1,5 m inside this area and prohibit access to unauthorised individuals.
	Make sure there are no leaks on the fittings and inspect the pipe for cracks or loose connections.
	Have to hand an appropriate fire extinguisher or suitably-sized spray filled with water
	Avoid wearing highly flammable nylon or similar clothing
	Wear heat-resistant gloves while using the device
	Maintain strict supervision for at least 2 hours after retraction.
	Check that the regulator fits properly with the gas cylinder.

This appliance is meant exclusively for professional use and for shrinking plastic films.

Users of the Ripack Series 3000 shrink gun must read this user's guide completely and must be trained for the applications that require the use of this appliance.

This user's guide must be kept for future reference.

Do not use this appliance for shrinking plastic film on materials, substances, products or liquids that inflame spontaneously, either processed in bulk or packed, and do not use the appliance in the storage areas of these products or in spaces where it is explicitly forbidden to smoke for safety reasons.

Do not use this appliance for shrinking plastic film on a floor that is made of combustible material (wood, plastic, etc.).

Close the valve of the gas bottle when not in use for long periods of time.

Press the trigger to empty the gas hose and release the pressure.

Never heat a specific area continuously.

Keep the working zone clean and remove all waste (wood, paper, other inflammable materials).

For all work inside professional workshops, the gas bottle must be placed on a mobile trolley that can be manoeuvred easily.

This appliance, like all other gas appliances, consumes air and produces combustion fumes that contain CO₂ and CO.

Exposure to high concentrations of the latter gas is lethal. Make sure there is sufficient ventilation in accordance with the amount of time the appliance is used (see "Technical Characteristics").

We recommend that the appliance be used in a room without specific pollution which has a minimum volume of 16 m³ (fresh air flow: 48m³/h).

Never work in a basement.

Before using the appliance, make sure that you are conforming to the guidelines for using liquid gas.



In operation, this appliance produces a flame. Do not point the flame towards yourself, other persons or animals, towards the gas bottle or the hose, or towards inflammable materials.

In operation, the appliance creates a danger zone up to 1.5 metres (5 feet) in front of the fire nozzle.

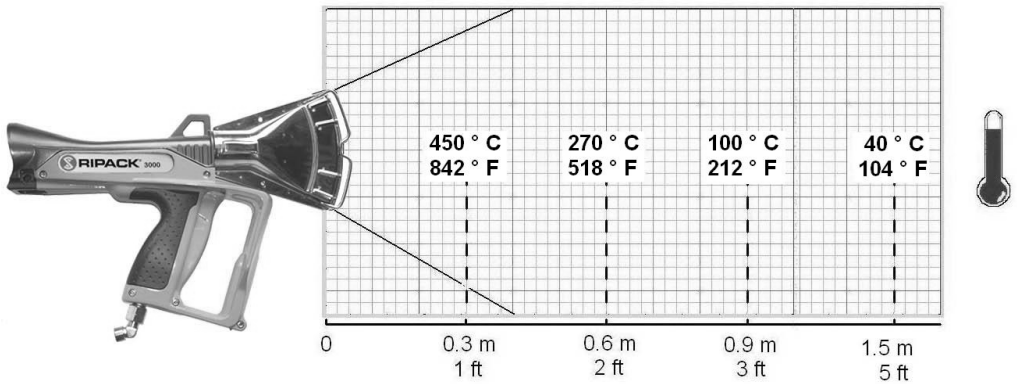

We draw the attention of operators to the fact that within the danger zone, there is a possible risk of burning for persons and animals, and goods can be damaged or catch fire.

In use, the gun must always be in motion so that the material used does not exceed the maximum temperature specified by the supplier.

This temperature depends on the operating distance, the exposure time and the power setting of the device.

This appliance, which is designed for applying plastic films by heating, can also be used for other purposes where the products can withstand the heat produced by a naked flame. Such use is explicitly the responsibility of the user. The manufacturer's guidelines of the product that is being handled must be followed at all times. In addition, the national, federal and local regulations with regard to the operation of appliances with a naked flame must also be respected.

To operate the appliance safely, you must follow the warnings mentioned above as well as the guidelines provided by the manufacturer of the materials being handled. The safety distance, the duration of exposure and the adjustment of the appliance for the different materials being handled, depend on the instructions provided by the manufacturer of the materials in question.

Always contact your RIPACK distributor for all maintenance work and spare parts.

The RIPACK Series 3000 propane works with propane according to the principle of atmospheric air burners induced at high speed (diagram B).

Ignition is performed using a piezoelectric lighter that is activated simultaneously with the release of gas activated by the trigger, which is the sole operating mechanism.

The RIPACK Series 3000 is a gun incorporating several safety mechanisms:

- Its original and patented design ensures combustion without heating the combustion nozzle (cold nozzle).
- A security valve system cuts off the gas supply in the event that the hose breaks or tears.
- An automatic safety device (so-called dead man's switch) cuts the supply of gas automatically if the trigger is released. This stops the heating immediately. This dead man's device must never be blocked in the open position in any way.
- A guard in front of the trigger prevents untimely operation

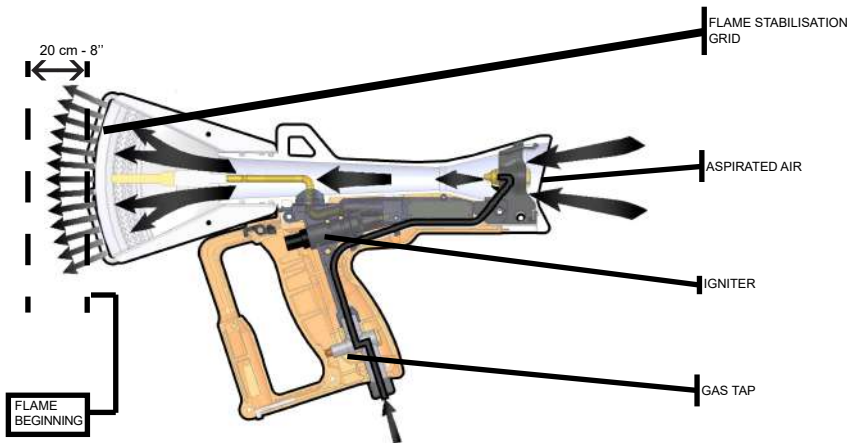

DIAGRAM B

PROPANE GAS APPLIANCE

TECHNICAL CHARACTERISTICS :

TABLE A

	SI SYSTEM
Pressure (bar)	1,5 to 3,5
Power (kW)	45 to 80
Consumption (kg/h)	3,06 to 5,41
Air intake (m ³ /h)	39 to 70
CO emission vol %	0,0052 to 0,0021
CO ₂ emission vol %	2,81 to 4
Noise level	< 85 dbA
Length	37,5 cm
Weight	1250 g
Energy source	Propane gas
Other energy source	Natural gas with conversion kit
	ANGLO-SAXON SYSTEM
Pressure (PSI)	21 to 50
Power (btu/h)	153 000 to 272 000
Consumption (lbs/h)	6,75 to 11,9
Air intake	1340 cu.ft/h to 2400 cu.ft/h
CO emission vol %	0,0052 to 0,0021
CO ₂ emission vol %	2,81 to 4
Noise level	< 85 dbA
Length	15 inches
Weight	2,7 lb
Energy source	Propane gas
Other energy source	Natural gas with conversion kit

OPERATION

Before operating the appliance you must read all the warnings mentioned above and make sure that using the appliance is not forbidden by the manufacturer of the materials that you are going to handle.

With this appliance you must use the ORIGINAL hose and SECURIPACK that were supplied.

FORBIDDEN WITH ALL USES



LIQUID PROPANE GAS
(e.g Fuel forklift truck)



BOTTLE ON ITS SIDE

The Ripack Series 3000 works with PROPANE gas in gas phase, contained in bottles of different capacities.

Use the largest possible bottles available.

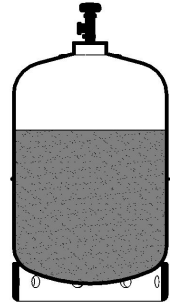

Always connect and disconnect the bottles a long way from any flames and ignition points.

For all work inside professional workshops, the bottle must be placed on a mobile trolley that can be manoeuvred easily.

CONNECTIONS

Before connecting the SECURIPACK to the gas bottle, make sure the sealing gasket is positioned correctly for systems using this type of joint.

In other cases, make sure the fitting is clean.

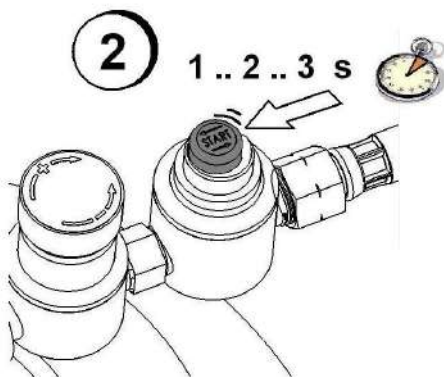
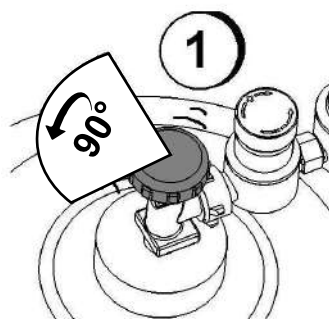
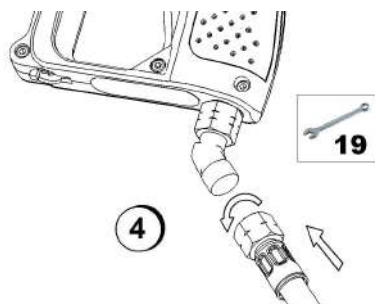
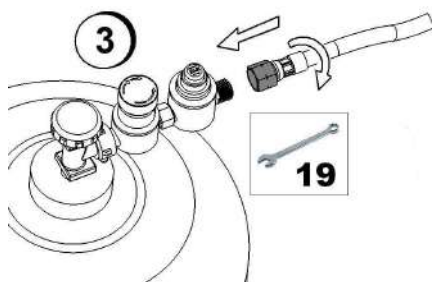
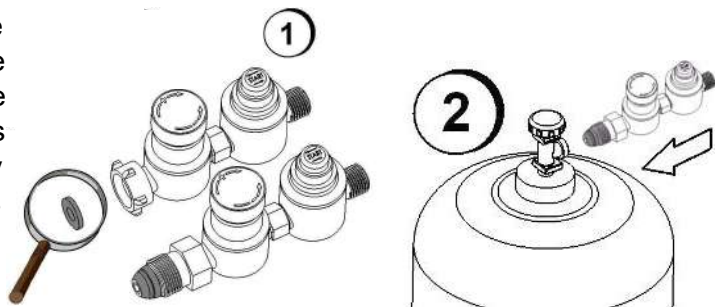

TIGHTNESS

Use a bubble spray or some soapy water to check that there are no leaks in the parts that have been screwed together (bottle, hose and gun connections)

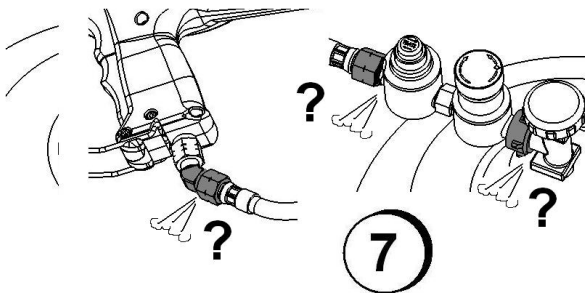

IGNITING THE RIPACK SERIES 3000

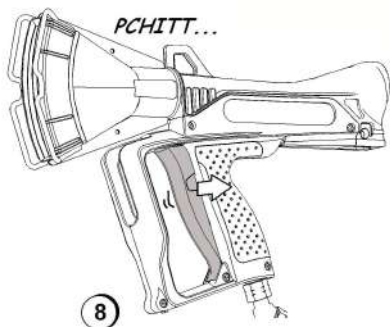

1s 

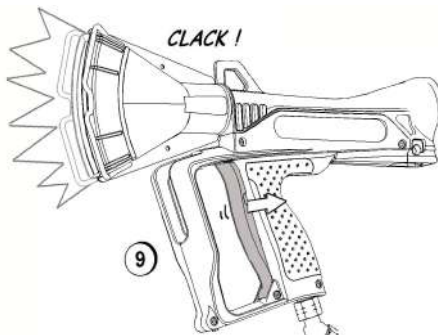

POWER KNOB

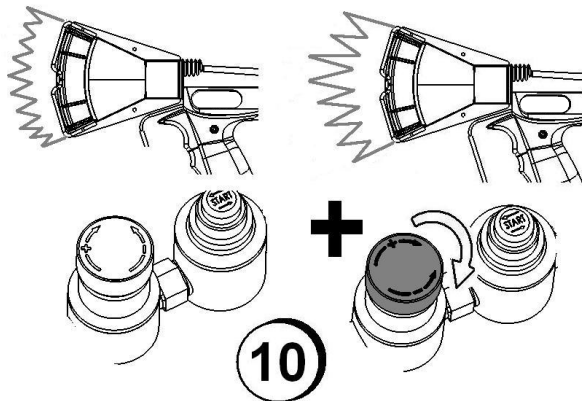

NEVER WORK WHILE HOLDING THE RED BUTTON

The SECURIPACK automatically cuts off the supply of gas if the pressure drops below the minimum level necessary for the normal efficiency of the work.

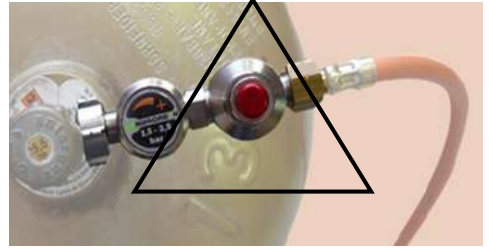

This is the case when:

- The bottle is nearly empty (the gun can only be used for a few more minutes at reduced power: change the bottle);
- The temperature of the bottle has dropped after intensive use (icing): if this is the case, change the bottle temporarily or wait until the normal pressure returns, especially if you are working outside (0°C / 30°F and colder).

NEVER HEAT A GAS BOTTLE WITH A FLAME.

WHEN YOU HAVE FINISHED WORKING, ALWAYS CLOSE THE GAS BOTTLE VALVE AND EMPTY THE HOSE BY PRESSING THE TRIGGER.



SPARE PARTS

THE COMPANY RIPACK SHALL NOT BE HELD LIABLE IN THE EVENT THAT THE GUN IS DISMANTLED.

Contact your dealer if the RIPACK Series 3000 needs to be dismantled.

Only the procedures described in the maintenance chapter are authorised.

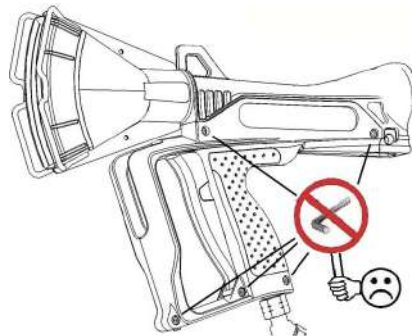

EXAMPLES OF USE

SHRINK-WRAPPING A LOADED PALLET

Ask your film supplier for the operating instructions.

The pallet must be lifted so that the four corners are accessible: the purpose of this is to allow the film to be shrunk under the pallet and so ensure very strong cohesion between the pallet and the load it supports. You will find an accessory in the RIPACK product range that is designed specially to keep pallets lifted from the ground: the CALPACK (contact your dealer).

Slide the shrink cover, which must be about 5% wider than your pallet and sufficiently long to be able to be shrunk under the pallet (H plus 200 mm).

Ignite your RIPACK Series 3000 as explained in the chapter "Operation".

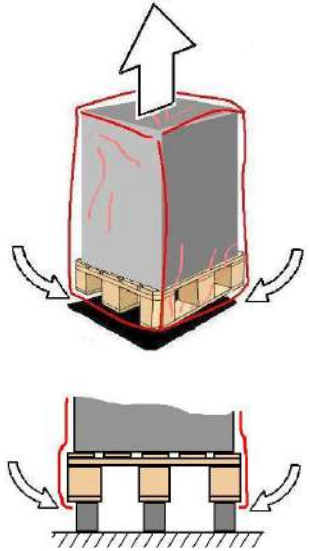

SHRINK-WRAPPING RECOMMENDATIONS

(in the absence of instructions provided by the film manufacturer):

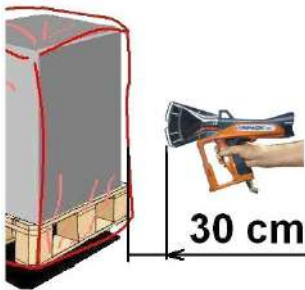

Remain at a distance of at least about 30 centimetres from the film and start shrink-wrapping the lower part of the four sides so the pallet is shrink-wrapped underneath. Make sure you point the air flow perpendicularly along the sides of the pallet.

Apply the heat in a continuous movement and at a constant speed.

NEVER STAY ON THE SAME SPOT

The various films react differently, so you must observe the reaction and adapt your speed and movement and/or the distance between the nozzle and the film accordingly.

You can also adjust the power of the RIPACK Series 3000 with the adjustable SECURIPACK controls.



Once the lower part of the pallet has been shrink-wrapped, continue the operation for each side and move from top to bottom to cover the entire height.

Once the 4 sides have been shrink-wrapped, you can do the top by applying the hot air to the top of the pallet.

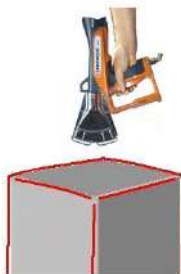

CAUTION: The film is already stretched along the sides so you should apply less heat on the top in order to prevent the cover from being damaged.

When you have stopped applying heat with the gun, the plastic film, because of its make-up, will continue to shrink for some time. This time will vary depending on the quality, the thickness and the type of load that has been wrapped. It is recommended therefore that you wait until the cover has cooled off and everything is tight before moving the pallet.

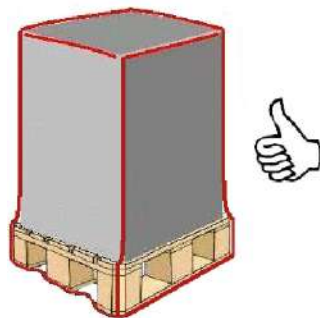

After cooling and before storage, always check that the cover and the wrapped goods are in good condition.

**CHECK CAREFULLY FOR AT LEAST 2 HOURS
AFTER SHRINK-WRAPPING.**

PACKAGING

All kinds of objects with irregular shapes can also be packaged using shrink-wrap film.

To obtain a good film joint, you need to provide a minimum overlap of 30 cm.

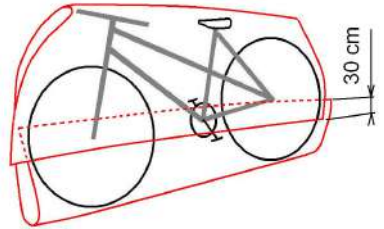

Start by heating the film in a continuous movement and then put pressure on this part to connect the two parts together.

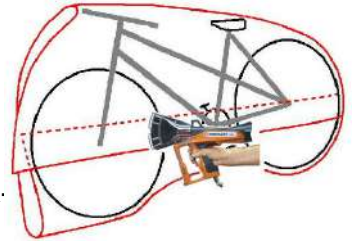

Once the joint has been made, continue the shrink-wrapping by holding the appliance at least 30 cm from the film. When doing this, be sure to follow the recommendations for shrink-wrapping.

NOTE : The combustion nozzle can rotate freely and this will make your work easier.

Put the nozzle in the required position.

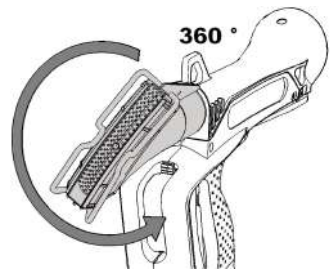

MAINTENANCE

MALFUNCTION DIAGNOSIS : NO GAS COMING OUT OF YOUR RIPACK 3000

CYLINDER
VALVE
CLOSED

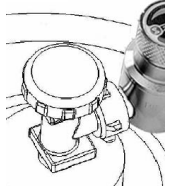

OPEN THE FAUCET
BY 90°

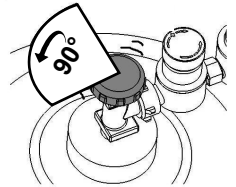

TOO HIGH
FLOW RATE



(The internal safety of the
gas cylinder can shut off
the flow if the valve
is opened too much).



CLOSE THE
VALVE

PURGE THE GAS
CIRCUIT IN THE
THERMAL LANCE.

REGULATOR IMPOSSIBLE
TO PRIME

1 .. 2 .. 3 s



CHANGE THE BOTTLE

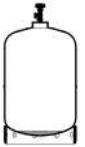

THE REGULATOR
ONLY WORKS
WITH PROPANE GAS



CONTINUOUS USE CAUSES THE
BOTTLE TO FROST

Provide a replacement cylinder
while the gas warms up.



BOUTEILLE
GIVREE

THE OUTSIDE TEMPERATURE
IS LOW

Store the bottles in a
temperate room.



TEMPERATURE
BOUTEILLE

NOTE: THE RED BUTTON CUTS OFF THE GAS SUPPLY BELOW A
PRESSURE THAT IS TOO LOW FOR THE OPERATION OF THE
RIPACK 3000.

NOTE: THE PRESSURE OF THE GAS IN A CYLINDER IS PROPORTIONAL TO THE TEMPERATURE OF THE GAS.

MALFUNCTION DIAGNOSIS :

DIFFICULTIES IN IGNITION OF YOUR RIPACK 3000

PIEZO USED



THE PIEZO LOSES ITS ELECTRICAL PROPERTIES WITH EACH SOLICITATION.

SPARE PIEZO REFERENCE :
131003

CHANGE THE PIEZO

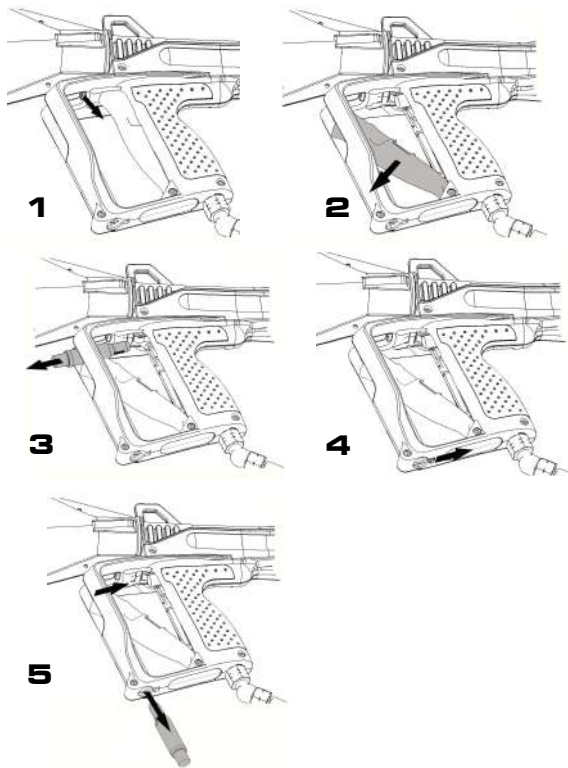

BROKEN SPARK PLUG

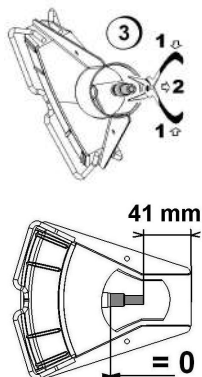

Remove the spark plug with flat pliers. Check the ceramic for cracks.

Change the spark plug if necessary. Be careful to clip the candle into its holder (it must not fall out).

OK

MALFUNCTION DIAGNOSIS :

DIFFICULTIES IN IGNITION OF YOUR RIPACK 3000

THE GAS FLOW RATE IS
ABNORMALLY REDUCED
(short and weak flame)

The ignition is not easy to do

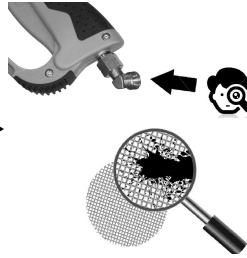

The swivel is equipped
with a grid filter.
This can be blocked by
the pollution of a gas
cylinder:

Remove the filter with a
pointed needle.
Reassemble after cleaning.

POLLUTED COMBUSTION
NOZZLE

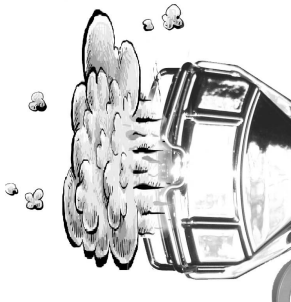

Clean the grid.

Thoroughly clean
the spark plug
housing which
mainly generates
the ignition
of the flame.

We recommend
the use of a
compressed
air blower.

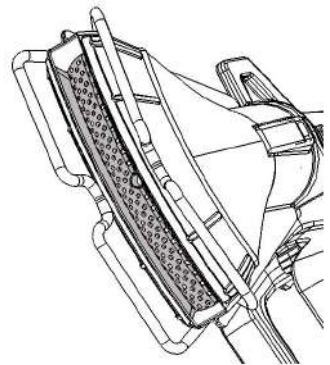

MALFUNCTION DIAGNOSIS :

NO GAS CUT-OFF AFTER RELEASING THE TRIGGER

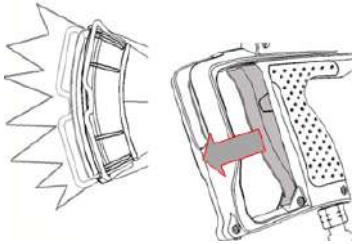

When the trigger is released, the combustion nozzle should shut off instantly. Otherwise :

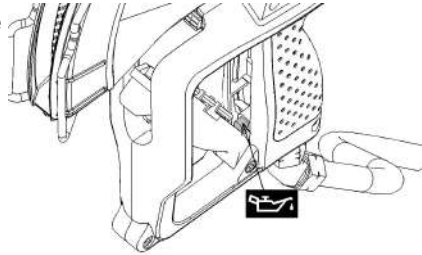

Open the trigger

Lubricate the piston of the dust-contaminated valve.

In case of repeated blockage, have the valve changed by your authorized Ripack dealer.

CHECKING THE SECURIPACK

THE CORRECT FUNCTIONING OF THE SAFETY MECHANISM MUST BE CHECKED FOR HOSE RUPTURE (INCORPORATED IN THE SECURIPACK) AT LEAST EVERY 500 HOURS OR EVERY THREE MONTHS. THIS IS TO BE PERFORMED AS FOLLOWS:

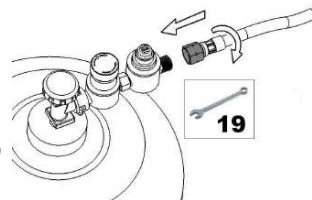

1. Go outside, a long way from any flame source, sparks and any objects that ignite
2. Apply pressure to the appliance. With the spanner supplied, loosen the connecting nut of the hose and unscrew completely: the gas supply will now be cut off automatically.

CHECKING THE RIPACK SERIES 3000:

DAILY BEFORE STARTING TO WORK:

1. Check the condition of the hose along its whole length and at the fittings. We recommend that you replace the hose in the following cases:

When a visual inspection has revealed damage (cuts), even if the damage is superficial.

Every 3 years if used intensively.

At the latest 5 years after first use

Note: The date on the hose is the manufacture date.

Only use a replacement hose supplied by RIPACK with its original fittings!

2. Check that the gas supply is shut off by releasing the trigger (see: no gas shut off on previous page).

WARRANTY

The products delivered by RIPACK® (SEFMAT Group) are covered by a contractual warranty for a period of ten (10) years from the date of delivery, covering any latent defect resulting from a defect in material, design or manufacture affecting the Ripack 3000 gun and rendering it unfit for use.

This contractual guarantee **applies only to the first purchaser of the Ripack 3000 gun after registration of the product on the RIPACK® website** at the following address <https://ripack.com/enregistrer-un-produit/>. For the application of This ten-year warranty requires that the Ripack 3000 gun must be registered within three (3) months of purchase.

The purpose of this warranty is to ensure the proper functioning of the Ripack 3000 gun that has suffered an internal breakdown. In order to assert his rights, the customer purchasing the Ripack 3000 gun must inform RIPACK®, in writing at the following address info@sefmat.com, of the existence of defects within a maximum period of seven (7) days from their discovery, under penalty of forfeiture of any action relating thereto.

The present warranty covers the costs related to the repair of the Ripack 3000 (parts, labor and return postage, the outward postage remains at the customer's expense) **or its replacement** (in the event that it is impossible to repair it). It does not entitle the customer to any compensation in kind or in cash.

The replacement of defective Products or parts will not have the effect of extending the duration of the above-mentioned warranty.

The warranty forms an inseparable whole with the Ripack 3000 gun sold by SEFMAT or its authorized dealer. The Ripack 3000 gun cannot be sold or resold altered, transformed or modified.

Our ten (10) year contractual warranty **DOES NOT APPLY** in cases of force majeure and does not cover :

- Deterioration, normal wear and tear of the product and in particular **the following wearing parts: piezo igniter #131003, spark plug #232061, gas hose #250023.**
- Accessories added after the purchase of the product (if applicable, a specific warranty related to the accessory concerned will apply)
- Defects due to damage, an accident or a fortuitous event or an accident resulting for example from a shock or a fall.

- Abnormal use, misuse or use under conditions different from those for which the product was manufactured, in particular in the event of failure to comply with the conditions prescribed in the RIPACK® instructions for use.
- Transformations of the product and in particular the modifications made or the addition of parts not coming from the manufacturer.
- Failure to regularly maintain the product as described on page 20 of the RIPACK user manual, negligence or failure to monitor the product on the part of the purchasing customer.
- Pre-existing repair of the product not provided by RIPACK® or an authorized RIPACK reseller.
- Products no longer bearing the label or identification number or products with a changed identification number.



GRUPE SEFMAT

RIPACK® 3000

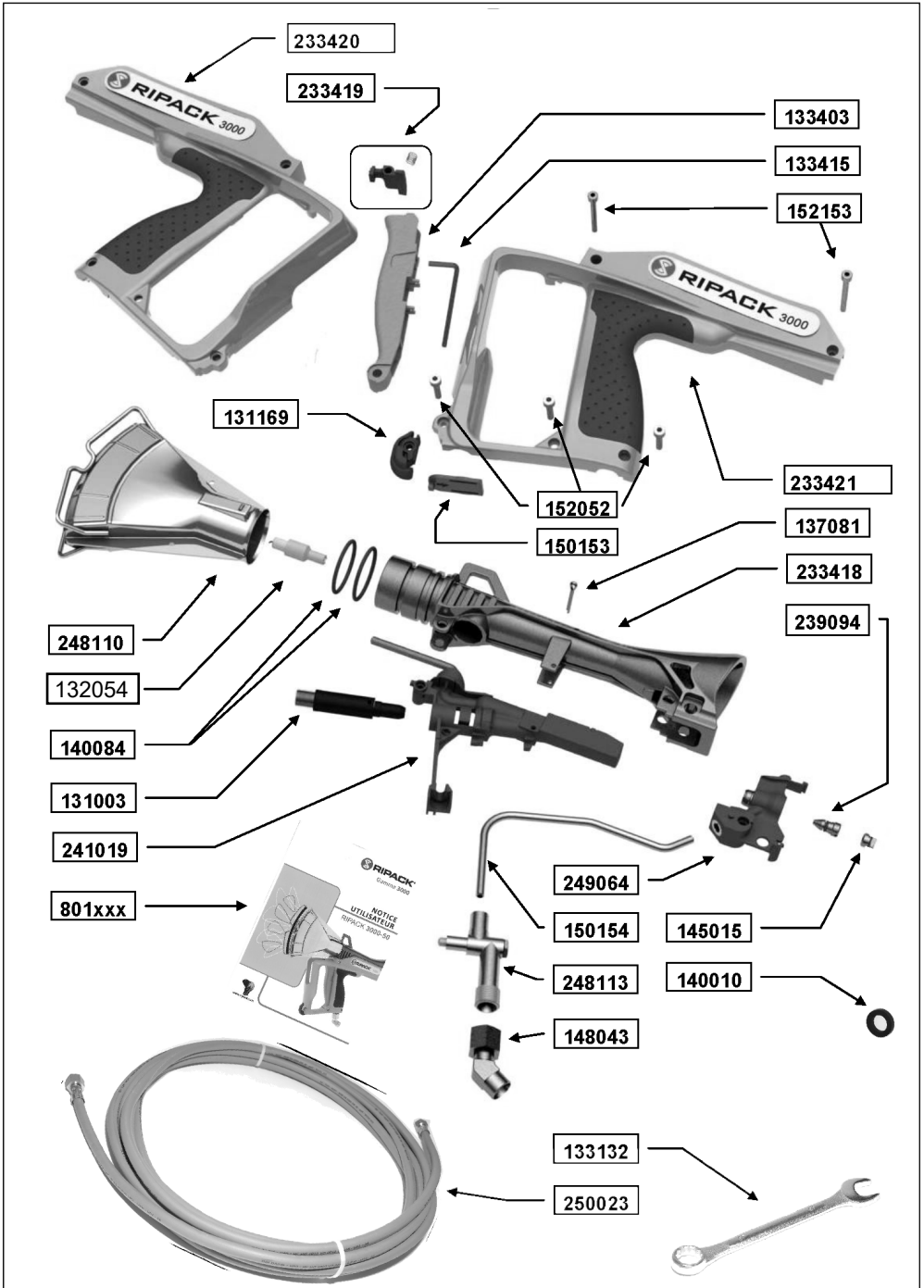



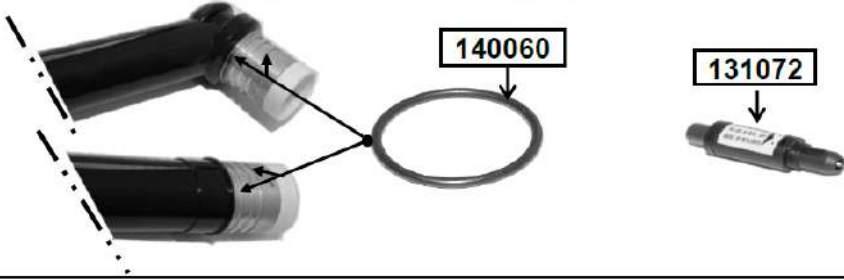

FOR EXTENSIONS ON RIPACK SERIES 3000



CHECK YOUR PRESSURE REGULATOR NUMBER →



NF		← 134022
UNI		← 134023
DIN		← 134024
USBS		← 134025

Code art.	Désignation
131003	Piezo igniter for standard RIPACK 3000 , without extension
131072	Piezo igniter for RIPACK 3000 with extension
131169	Bumper
133132	Wrench 19
133403	Trigger
133415	Allen key 3
137039	Molykote grease
137081	Ground pin
140010	Flat seal for SECURIPACK NF - UNI
140061	O-ring inside Ø 28.24 x 2.62 DIN for extensions
140084	O-ring inside Ø 34,82 x 3,53 DIN
145015	Jet cover nut RIPACK Series 3000
148043	Swivel connector
150153	Piezo Trap
150154	Aluminium gas feed tube
152052	Screw M4x16
152153	Screw M4x35
132054	Spark plug
233418	Body with O-rings DIN
233419	Pawl + Spring
233420	Half-handle, right + RIPACK 3000 label
233421	Half-handle, left + RIPACK 3000 label
239094	Standard jet - propane - DIN
241019	Electrical Connection Kit / standard RIPACK Series 3000
241020	Electrical Connection Kit / RIPACK Series 3000 with Extension
248110	Combustion nozzle
248113	Gas tap, DIN
249064	Jet bearer complete DIN (includes : bearer, jet, jet cover nut)
250023	High pressure hose, DIN, Length 8 meters, inside Ø: 4, with clamps and fittings
801xxx	User's manual RIPACK 3000



DÉCLARATION DE CONFORMITÉ CE
EC- DECLARATION OF CONFORMITY
CE - KONFORMITÄTSERKLÄRUNG

Le fabricant soussigné :
The manufacturer undersigned :
Der unterzeichnete Hersteller :

SEFMAT S.A.S, 7 RUE DE BETNOMS, 33185 LE HAILLAN, FRANCE

Déclare que l'appareil :
Hereby declares that the appliance :
Erklärt hiermit, dass das Gerät :

RIPACK 3000

déstiné à la production d'une flamme produite par la combustion de gaz
designed to produce a flame produced by the combustion of gas
zue Erzeugung einer durch Verbrennung von Gas erzeugten Flamme bestimmt ist,

est conforme aux dispositions du Règlement (UE) 2016/426 du 9 mars 2016 concernant les appareils brûlant des combustibles gazeux.

is in accordance with the Regulation (EU) 2016/426 of 9 March 2016 on appliances burning gaseous fuels.
den Anforderungen der Verordnung (EU) 2016/426 vom 9. März 2016 über Geräte zur Verbrennung gasförmiger Brennstoffe entspricht.

Cette conformité est confirmée par le laboratoire DVGW CERT sous le numéro DG-2418BR0325.
This conformity is confirmed by the DVGW CERT laboratory under number DG-2418BR0325.
Diese Konformität ist vom DVGW-CERT-Labor unter der Nummer DG-2418BR0325 bestätigt.

Fait au Haillan, le 1er septembre 2016
Le Haillan, September 1st, 2016
Le Haillan, 1. September 2016

Le Président
President
Vorstandsvorsitzender



CERTIFICATIONS INTERNATIONALES
WORLD CERTIFICATIONS

